

# Operation

## ⚠️ DANGER

- Ensure that all connections are properly torqued and enclosure is closed prior to applying power to the device.
- Ensure all mechanical equipment operated by the starter is clear for safe operation in case of starter activation.
- When in AUTO mode, starter may be activated remotely by the control system

### Keypad Interface

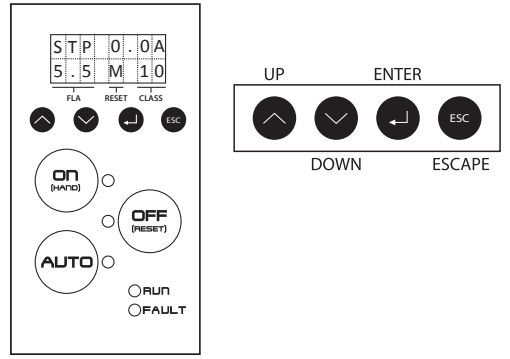

### Operation Modes

- ON (HAND)**  
Press the ON mode button to manually engage motor.
- OFF (RESET)**  
Pressing the OFF mode button manually disengages the motor. Additionally, the OFF button serves as a manual Reset. Press and hold OFF for 5 seconds to Reset the starter after a fault trip.
- AUTO**  
When utilizing AUTO mode, the starter is controlled by a remote Start/Stop command.

### LED Status Indicators

- MODE LEDs**  
Illuminates with corresponding mode selection (HAND/OFF/AUTO). Flashing mode LED signals a fault trip during the last operating mode. All 3 mode LEDs will flash simultaneously during Shutdown or Fireman's Override operation.
- RUN LED**  
Illuminates when starter is given a Run signal and proof of power is detected. LED will flash when Run signal is present without proof of power to the motor.
- FAULT LED**  
Illuminates upon a fault condition or overload trip. Starter must be returned to the OFF mode in order to Reset. A 180 second minimum cool down period must elapse prior to further operation.

### Lockout Settings & Overload Adjustment

The EMS Starter is pre-configured to protect the motor based on customer selected specification. If adjustments need to be made to any of the protective functions of the EMS starter, the settings must first be unlocked. To unlock the EMS settings, follow the steps below.

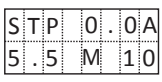

#### Default Display Screen

- Press and hold the UP and DOWN buttons for 2 seconds until the display screen matches the display at left.
- Press the ENTER button to change the menu from "LOCKED" to "UNLOCKED."
- The lockout feature is now disabled. Press the ESC key to return to the Default Display screen.

Adjustments may now be made to the Overload FLA setting and Ground Fault Level setting. The lockout feature will automatically re-enable itself after 2 minutes.

#### Overload Adjustment (Setting Range 1.0 - 95.0 Amps)

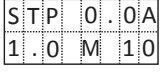

Once settings are unlocked, follow the steps below to adjust overload setting.

- Press the DOWN arrow once.
- Press ENTER
- Use the UP and DOWN keys to make adjustments.
- Press ENTER to save setting.
- Press ESC to return to the Default Display screen.

Product improvement is a continual process. Cerus, Mira, Orion and associated logos are trademarks of Cerus Industrial Corp. All sales subject to Cerus Terms & Conditions.

# Wiring Schematic

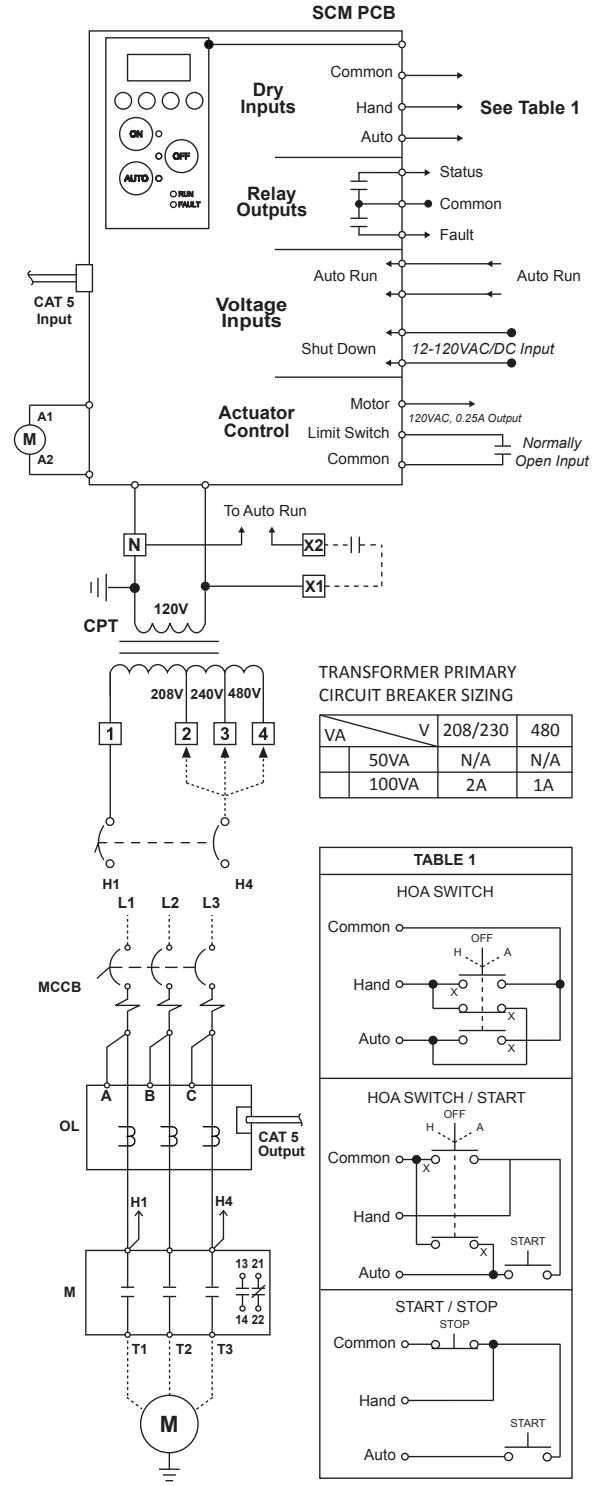

With Ethernet Fault Logging

## Installation & Operation

This is a condensed version of the full manual. The complete manual is available for download at [www.cerusind.com](http://www.cerusind.com) or call 800.962.3787.



### Precautions

To prevent injury and property damage, follow these instructions. Failure to adhere to installation/operation procedures and all applicable codes may result in hazards as indicated by warning codes outlined below:

**⚠️ DANGER**  
indicates an imminently hazardous situation which, if not avoided, will result in death or serious injury. This signal word is to be limited to the most extreme situations.

**⚠️ WARNING**  
indicates a potentially hazardous situation which, if not avoided, could result in death or serious injury.

**⚠️ CAUTION**  
indicates a potentially hazardous situation which, if not avoided, may result in minor or moderate injury. It may also be used to alert against unsafe practices.

**⚠️**  
This is the safety alert symbol. Read and follow instructions carefully to avoid a dangerous situation.

**⚡**  
This symbol alerts the user to the presence of "dangerous voltage" inside the product that might cause harm or electrical shock.

### Safety Instructions

- ⚠️ DANGER**  
Equipment can start automatically. Lockout/tagout before servicing.
- ⚠️ CAUTION**  
As with all electrical products, read manual thoroughly. Only qualified, expert personnel should perform maintenance and installation. Contact the nearest authorized service facility for examination, repair, or adjustment. Do not disassemble or repair unit unless described in this manual; death or injury to electrical shock or fire hazard may result. Specifications and manual data subject to change. Consult factory for additional information.

# Installation



## HAZARDOUS VOLTAGE

- Disconnect and lock out all power before installing or servicing equipment.
- This equipment may require locking out multiple power sources prior to service
- Install and wire in accordance with all applicable local & national electrical and construction codes

## FAILURE TO FOLLOW THESE INSTRUCTIONS MAY RESULT IN DEATH OR SERIOUS INJURY

### Mounting

Mount the starter on a vertical surface, with the line terminals facing up. Install using 1/4" diameter hardware suitable for the mounting surface.



- To maintain overcurrent, short-circuit, and ground-fault protection, the manufacturer's instructions for selecting current elements and setting the instantaneous-trip circuit breaker must be followed.
- Tripping of the instantaneous-trip circuit breaker is an indication that a fault current has been interrupted. Current-carrying components of the magnetic motor controller should be examined and replaced if damaged to reduce the risk of fire or electric shock. If burnout of the current element of an overload relay occurs, the complete overload relay must be replaced.
- Do not locate starter in an environment subject to flammable gases, dusts or materials. Contact arcing can induce explosion or fire.
- Locate starter in a location appropriate to enclosure ratings and operational ratings.  
(e.g. NEMA 1 should only be located in a dry, protected environment).
- Do not allow any metal shavings or debris from installation to enter enclosure.

### Wiring

Wire main power input and motor leads to the appropriate terminals tightened to specified torques indicated in the Torque Table below. Use only copper conductors rated at least 60°C for applications less than 100A and at least 75°C ≥ 100A. Maintain proper clearances and verify that no possibility of an electrical short exists between the power conductors or enclosure. Ensure that wires are not under stress and all insulation is intact. Verify voltage input matches label and the control power is tapped per schematic.

### Low Voltage Wiring

Control wiring should be run in a separate conduit. The control terminals accept 26~14AWG wire torqued to 3.5 in-lb.

### Torque Table

NEMA Size	Input (lb-in)	
	Circuit Breaker	Motor Leads
1	70	20
2	70	35
3	70-132	45
4	132	80-86
5	442	300-390

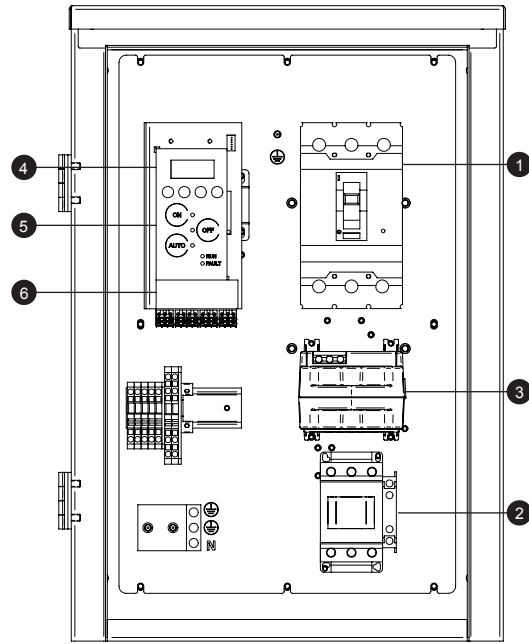

- 1 Circuit Breaker Disconnect
- 2 Magnetic Contactor
- 3 Overload Meter Base
- 4 LCD Display & Program Buttons
- 5 Hand-Off-Auto Keypad
- 6 Control Terminal Inputs/Outputs

## Control Terminals

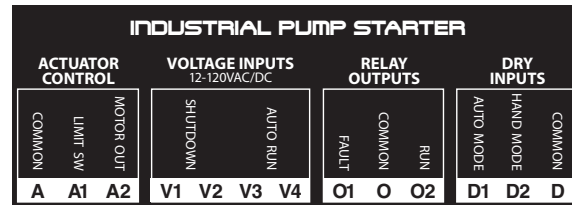

<b>Actuator Controls</b>	Interlocks starter with dampers or valves. Motor output provides power to actuator motor (1A maximum @ 24VAC or 0.25A @ 120VAC). Starter enables motor operation upon Limit Switch contact closure.
<b>Voltage Inputs</b>	The Auto Run inputs are wired a terminal block for easy connection (terminals X1 & X2). Shutdown mode is activated by applying 12~120 VAC/DC to terminals V1 & V2.
<b>Relay Outputs</b>	Confirm motor operation (status) or indicate fault conditions (starter trip). Can be used to activate signaling devices such as lights or horns.
<b>Dry Inputs</b>	By default, the dry inputs are wired to door mounted pilot devices.

# Ethernet Connections

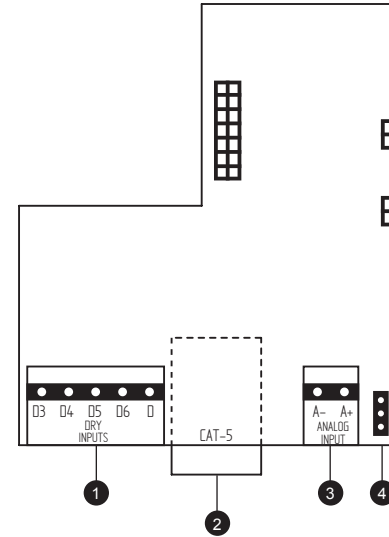

- 1 Dry Contact Inputs
- 2 Ethernet Cable Connection
- 3 Analog Input
- 4 Analog Input Selector Jumper

<b>Dry Contact Inputs</b>	Dry input terminals. Normally open contacts or transistorized inputs.
<b>Ethernet Cable Connection</b>	CAT-5 Cable with RJ-45 Connection
<b>Analog Input</b>	Analog input for 4-20mA, 0-10V or 10KΩ thermistor.
<b>Analog Input Selector Jumper</b>	<b>No Jumper:</b> 0-10V Input <b>Jumper Pin 1 &amp; 2:</b> 10KΩ Thermistor Input <b>Jumper Pin 2 &amp; 3:</b> 4-20mA Input



- Replace battery with Renata SA, Part No. CR2032RV MFR only. Use of another battery may present a risk of fire or explosion. Contact Cerus Industrial for replacement batteries.
- Battery may explode if mistreated. Do not recharge, disassemble or dispose of in fire.

# Ethernet Setup

## Establishing Ethernet Connection

- Turn off and disconnect power to the starter
- Connect ethernet cable from the starter's CAT-5 terminal to one of the following:
  - 1) Personal computer (PC will assign IP address)
  - 2) Network (Router will assign IP address)
- After establishing connections, return power to the starter
- Obtain IP address by following the steps below:

## Display Screens:

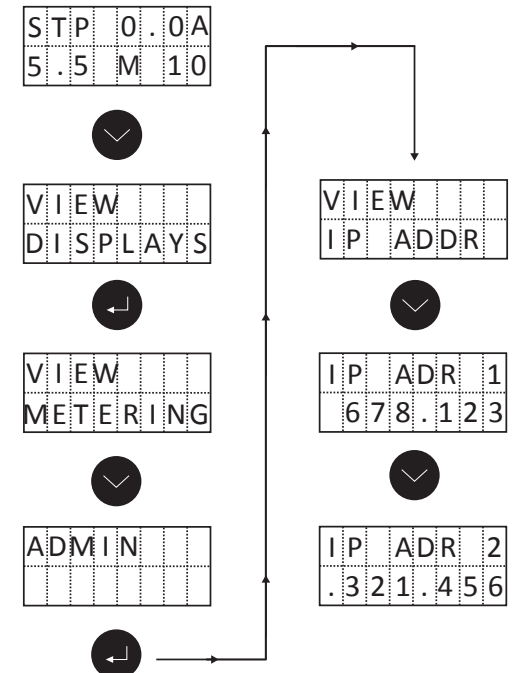

- In web browser, type IP address (IP address = IP ADR 1 + IP ADR 2)
- After web page loads the user can set the location, description, date, time and view fault history