



CERUS
INDUSTRIAL®

Installation, Operation, & Maintenance Manual



BACnet®

for the

BASSTARTER



- **Be cautious when handling the CMOS components of the BACnet board.**

Static electricity may cause the product to malfunction.



- **Disconnect power to the starter prior to changing the communication cable.**

Otherwise, you may damage the board or a communication error may occur.

- **Make sure the BACnet board is properly seated on the main board.**

Otherwise, you may damage the board or a communication error may occur.

- **Verify all parameters are correct during installation.**

Otherwise, a communication error may occur.



CERUS
INDUSTRIAL®

The Direct Source for Motor Controls™

1.800.962.3787 • www.cerusind.com • thestarterguys@cerusindustrial.com

Table of Contents

- 1. Introduction 2
- 2. Hardware Components 3
 - 2.1 Detailed Component Descriptions 5
 - 2.1.1 Status LED Definitions 5
 - 2.1.2 DIP Switch Settings..... 7
 - 2.2 SBC Interfaces 13
- 3. BACnet Protocol 14
 - 3.1 Performance..... 14
 - 3.2 LAN Media 14
 - 3.2.1 Support for MS/TP 14
 - 3.3 BIBB Support 14
 - 3.4 The Object Model 14
 - 3.4.1 Object/Property Support Matrix..... 14
 - 3.4.2 Device Object Support 16
 - 3.5 Object Support (in general)..... 17
 - 3.6 Commandability 17
 - 3.7 Writability 17
 - 3.8 Segmentation 17
- 4. Configuration 18
- 5. Quick Communication Setup 19
- 6. Interface Table 20
 - 6.1 Binary Value Object Instance Summary..... 20
 - 6.2 Binary Input Object Instance Summary 21
 - 6.3 Multi-state Input Object Instance Summary..... 24
 - 6.4 Analog Value Object Instance Summary..... 25
- 7. Diagnostics 26

1. Introduction

The STR-BN-COM (SBC) option board is an option for Cerus BAS Starters, providing Building Automation and Control Network (BACnet) Master Slave Token-Passing (MS/TP) data link protocol communications.

BACnet was created by ASHRAE to allow computer-based control equipment from different manufacturers to communicate with each other. BACnet is designed to handle many types of building controls, including HVAC, lighting, security, fire, access control, maintenance, waste management, etc.

Features

- Embedded and Native communications for clean installation and fast response times
- Field selectable baud rates up to 76,800
- Start, stop and reset control via BACnet
- Operational monitoring of values such as Proof of Flow via BACnet
- Galvanically isolated output

Technical Summary

Connection	Interface	3 Pin Pluggable Connector
	Data Transmission Method	RS-485 MS/TP, Half-duplex
	Cable	Twisted pair (1 pair and shield)
Communication	BACnet MS/TP	ANSI/ASHRAE Standards 135-2004
	Baud Rate	9600, 19200, 38400, 76800
	MAC Address	0-127

2. Hardware Components

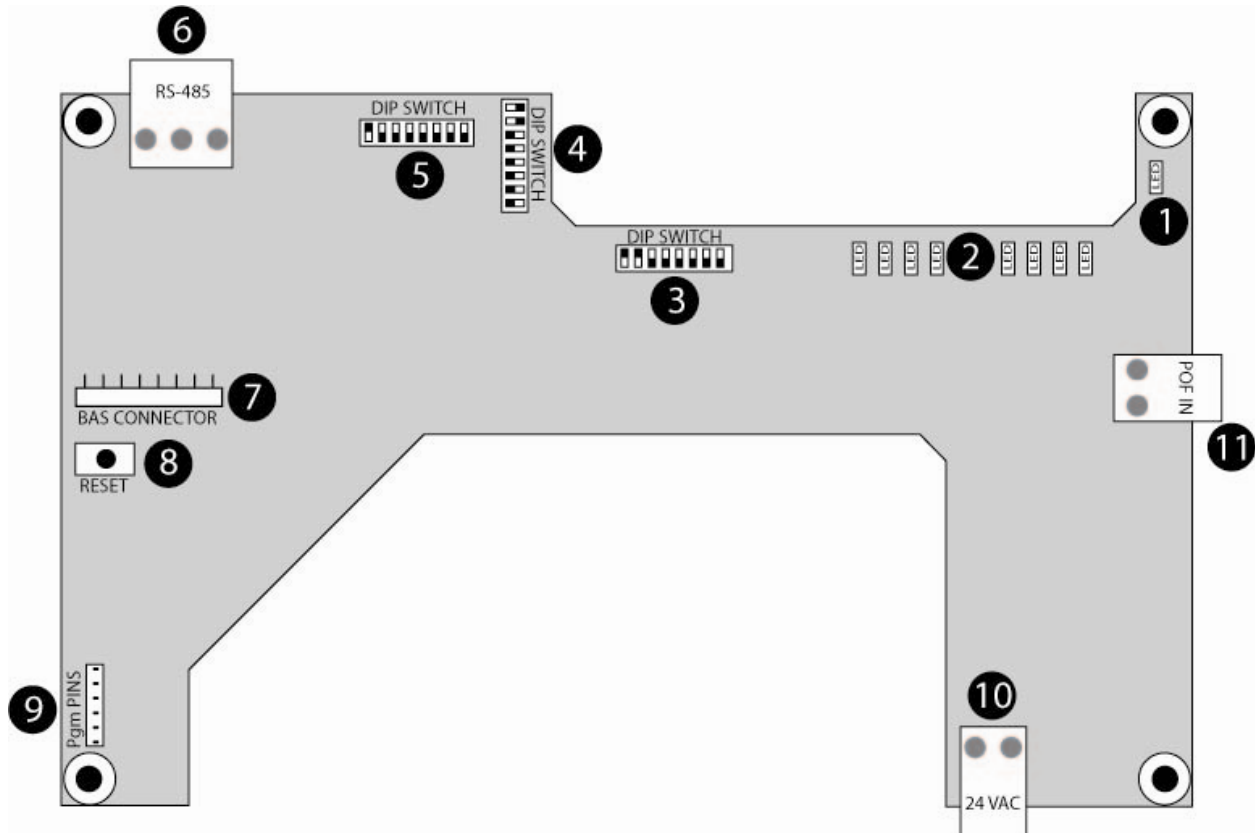

Figure 1. Board Layout

- 1) Power LED
Green LED; On - indicates power applied to board
- 2) Status LEDs (CPU, TX, RX, TOK, ERR, ON, F1, F2)
See section 2.1.1 for definitions.
- 3) Baud Rate DIP Switch
See section 2.1.2 for settings.
- 4) Device Address DIP Switch
See section 2.1.3 for settings.
- 5) Term/Bias Options DIP Switch
See section 2.1.4 for settings.
- 6) RS-485 Communications Interface
Connect the RS-485 connector into these terminals.

- 7) BAS Board Connector
This connector connects the BACnet SBC daughter board to the BAS Starter board. Connector on back of SBC connects to connector on front of BAS Starter board.
- 8) RESET Button
This button will reset the SBC (Note: This will not reset the starter main board).
- 9) Programming Pins
The program pins are used to program the CPU at the factory.
- 10) 24 VAC Input
This is the 24VAC input from the control power transformer (CPT) that resides within the BAS Starter.
- 11) POF Input Terminal
This is a NO dry contact to receive Proof of Flow (POF) input from the current sensor that resides within the BAS Starter. When closed, Proof of Flow is indicated.

2.1 Detailed Component Descriptions

2.1.1 Status LED Definitions

Following a power on reset, all eight Status LEDs should flash briefly to indicate a restart. Their states and functionality are described below.

LED Name	Color	Description
CPU	Green	<p>The CPU LED provides the “heartbeat” indication for the SBC indicating that it is operating normally.</p> <p>Off – No power to SBC or SBC malfunction.</p> <p>Blink – During normal operation of SBC, the CPU LED will blink at a one second rate.</p>
TX	Green	<p>The TX LED is turned on when the SBC is transmitting on the MS/TP EIA485 port.</p> <p>Slight Flicker – The SBC is the only BACnet device on the MS/TP network.</p> <p>Variable On – The SBC is not the only BACnet device on the MS/TP network and the TX LED will cycle on and off with a frequency depending on the number of devices and how much communication there is to the SBC.</p>
RX	Green	<p>The RX LED is turned on when the SBC is receiving data on the MS/TP EIA485 port.</p> <p>Off – The SBC is the only BACnet device on the MS/TP network</p> <p>Variable On – The SBC is not the only BACnet device on the MS/TP network and the RX LED will cycle on and off with a frequency depending on the number of devices and how much communication there is to the SBC.</p>
TOK	Red	<p>The TOK LED is turned on when the SBC possesses the MS/TP Token.</p> <p>On – The SBC is the only BACnet device on the MS/TP network.</p> <p>Variable On – The SBC is not the only BACnet device on the MS/TP network and the TOK LED will cycle on and off with a frequency depending on the number of devices and how much communication there is to the SBC.</p>

ERR	Red	<p>The ERR LED is used to indicate an error in communications with the main BAS board.</p> <p>Off – There are no errors in SBC to main BAS board communication.</p> <p>Variable On – There are errors in the SBC to main BAS board communication as further defined by F1 and F2 LEDs.</p> <p>If there is an error, the ERR LED will remain on for approximately two seconds.</p>
ON	Red	<p>The ON LED is used to indicate Proof of Flow.</p> <p>Off – No Proof of Flow</p> <p>On – Proof of Flow</p>
F1, F2	Both Yellow	<p>As long as the ERR LED is off, the F1 and F2 LEDs cycle on and off together indicating normal activity between the SBC and main BAS board. The cycling from both on to both off or from both off to both on indicates one complete read/write cycle of the BAS variables. These LEDs should blink at approximately a two second rate during normal operation.</p> <p>ERR LED OFF and F1 & F2 ON together/off together – Healthy communications between SBC and main BAS boards</p> <p>ERR LED ON and</p> <p>F1=ON,F2=OFF – Indicates timeout between SBC and main BAS boards</p> <p>F1=OFF,F2=ON – Indicates other communication error between SBC and main BAS boards (i.e. overrun, missing byte, H/W overrun etc.)</p>

2.1.2 DIP Switch Settings

2.1.2.1 Baud Rate DIP Switch Settings

The 8 position Baud Rate dip switch has the following default setting and definition:

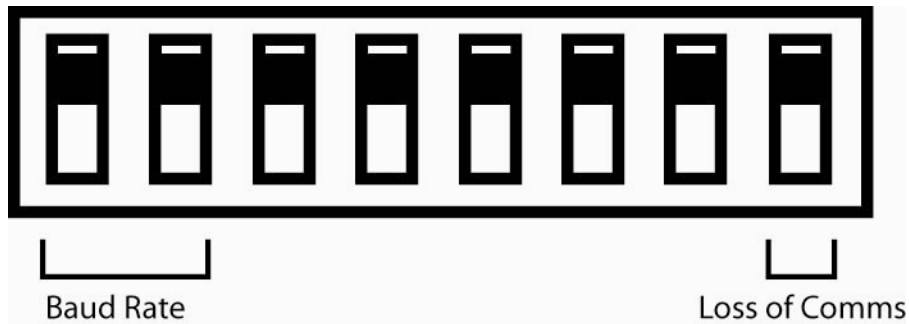

Figure 2. Default DIP Switch 1 Settings

Switch 1 and 2, MS/TP baud rate:

Baud Rate	Switch 1	Switch 2
9600	OFF	OFF
19200	ON	OFF
38400	OFF	ON
76800	ON	ON

Switch 3 through 7, unused

Switch 8, Loss of BACnet Communication:

Action	Switch 8
Do not change BV1 (AutoStartCommand) when BACnet communications are lost*	OFF
Set BV1 (AutoStartCommand) =0 when BACnet communications are lost*	ON

* Note: The SBC detects BACnet communications by the receipt of any ReadProperty or WriteProperty request, which when received resets a running seconds counter in the SBC. The running counter is checked against the BACnet object AV2 (CommTimeout in seconds) and indicates Loss of Communications if exceeded.

2.1.2.2 Device Address DIP Switch Settings

The 8 position Device Address DIP switch is used to configure the MS/TP MAC address. The 8 position Baud Rate dip switch has the following default setting and definition:

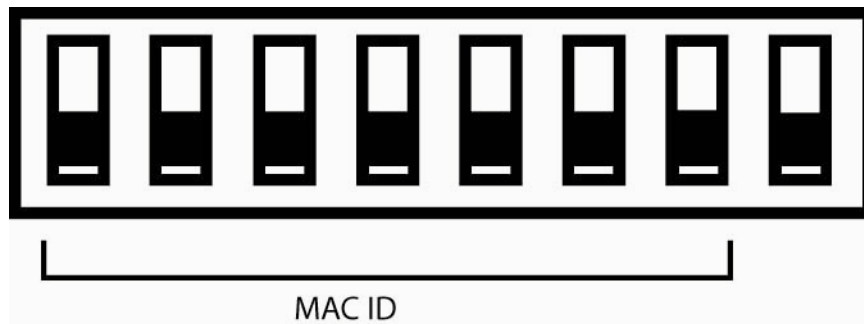

Figure 3. Default DIP Switch 2 Settings

Each master device on the MS/TP daisy chain must have a unique Media Access Control (MAC) address (0-127). The switches represent the binary pattern of the MAC address, where Switch 1 is the least significant bit, and Switch 7 is the most significant bit.

The MAC ID Address Values Table below can be used to create a MS/TP MAC ID Address.

For example, to select an address of 7, set switches 1, 2 and 3 to ON and the remaining DIP switches to OFF ($1+2+4 = 7$).

MAC ID Address Values	
Switch	Value
1	1
2	2
3	4
4	8
5	16
6	32
7	64

2.1.2.3 Term/Bias Options DIP Switch

The 8 position Term/Bias Options DIP switch has the following default setting and definition:

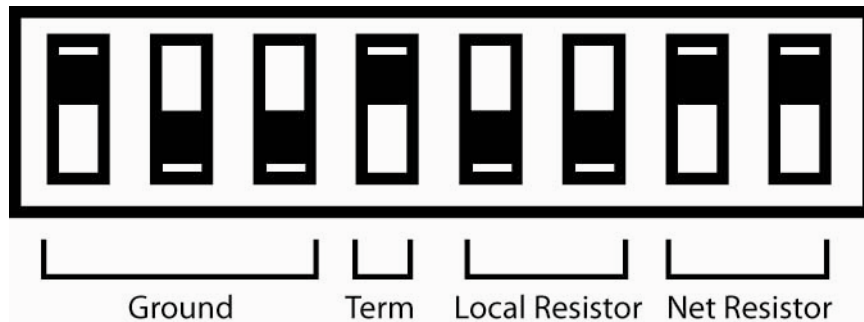

Figure 4. Default DIP Switch 3 Settings

Switch 1 - 3 = RS-485 shield conductor connection to (isolated ground):

Ground Connection	Switch 1	Switch 2	Switch 3
Direct	ON	-	-
None	OFF	OFF	OFF
Through 1M resistor	OFF	ON	OFF
Through .001uF capacitor	OFF	OFF	ON
Through 1M resistor and .001uF capacitor	OFF	ON	ON

Per the BACnet Standard, each shield shall be grounded at one end only to prevent ground currents from being created.

For convenience, the following options are available and described below:

- Direct – Connect shield(s) directly to ground reference.
- None – Shield is not connected to ground reference
- Through 1M resistor – Connect shield(s) to ground reference through a 1M resistor. This is useful for allowing the shield to float (to bleed off large common mode voltages), but to limit any large ground currents. If the shield conductor(s) are connected to ground at another location, then this DIP switch may be selected.
- Through .001uF capacitor – Connect shield(s) to ground reference through a .001uF capacitor. This is used only in those situations called for in a specially designed grounding scheme. This allows a return path to ground for high frequency signals while blocking DC currents.
- Through 1M resistor and .001uF capacitor – Connect shield(s) to ground reference through both a 1M resistor and .001uF capacitor. This is useful in providing a high impedance DC reference while blocking large DC and low frequency currents.

Switch 4, Enable network termination resistor:

Action	Switch 4
Don't enable network termination resistor	OFF
Enable network termination resistor	ON

Switches 5 & 6, Enable local bias resistors:

Action	Switch 5	Switch 6
Don't enable local bias resistors	OFF	OFF
Enable local bias resistors	ON	ON

Switches 7 & 8, Enable network bias resistors:

Action	Switch 7	Switch 8
Don't enable network bias resistors	OFF	OFF
Enable network bias resistors	ON	ON

Per the BACnet Standard, the following describes the resistor options:

- A termination resistor must be connected at each of the two ends of the segment medium. No other termination resistors are allowed at intermediate nodes.
- At least one set, and no more than two sets, of network bias resistors shall exist for each segment. If two sets of network bias resistors are provided, they shall be placed at two distinct nodes, preferably at the ends of the segment.
- The use of local bias resistors is optional.

The following figure shows the hardware effects of modifying the bias resistors:

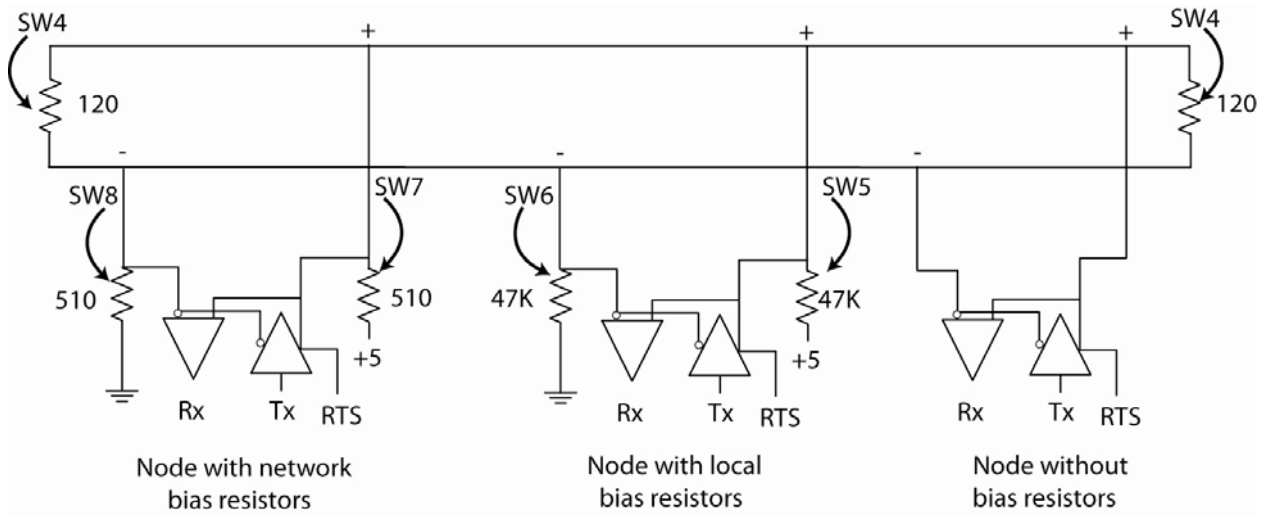

Figure 5. Bias Resistors

2.2 SBC Interfaces

Figures 6 and 7 show the external operational interfaces of the SBC for single-phase and three-phase operation. The SBC is depicted showing the Proof of Flow input from the Current Sensor, the 24V power input from the secondary output of the Control Power Transformer and the BACnet I/O via the RS-485 I/O Port.

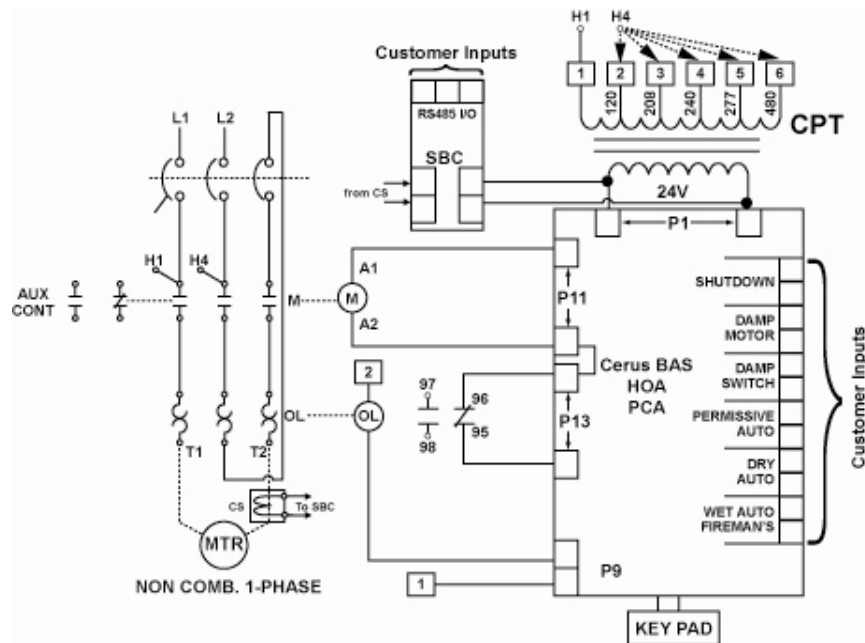

Figure 6. SBC Operational Interfaces for a single-phase BAS Starter

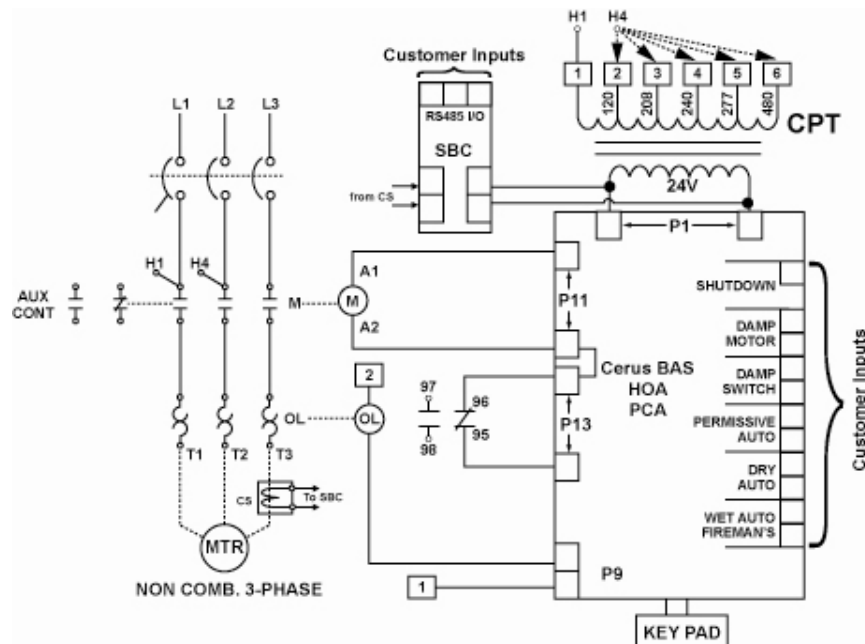

Figure 7. SBC Operational Interfaces for a three-phase BAS Starter

3. BACnet Protocol

The **SBC** IS be implemented to meet the most up-to-date model of BACnet capabilities. Where applicable, implementation supports ISO 16484-5, ANSI/ASHRAE 135-2004 and all relevant errata. Other specific BACnet features and requirements are detailed in the following numbered paragraphs:

3.1 Performance

The **SBC** provides for synchronous MSTP request traffic. Incoming packets accommodate large (501 bytes or less) packets based on the assumption that all requests can be answered immediately without requiring Reply_Postponed. The design incorporates capabilities for up to four pending transmit packets.

3.2 LAN Media

The **SBC** supports one type of LAN media: MS/TP over EIA-485.

3.2.1 Support for MS/TP

- Full Master Node state machine
- Media Access Control (MAC) ID, Baud rates of 9600, 19200, 38400 and 76800 configurable via Dip Switches
- Device Instance, Max Master, Description and Location configurable via BACnet interface via Device Object. For simplicity, Device Instance is also configurable via Analog Value.

3.3 BIBB Support

The **SBC** supports the following specific BIBBs per their relevant definitions in Annex K to BACnet:

- DS-RP-B, DS-RPM-B, DS-WP-B, DS-WPM-B i.e. act as a server that can execute Read/Write single or multiple properties.
- DM-DDB-B, DM-DOB-B i.e. dynamic device and object binding. Support initiating I-Am in response to Who-Is and I-Have in response to Who-Has.

3.4 The Object Model

3.4.1 Object/Property Support Matrix

The following table summarizes the Object Types/Properties Supported:

Property	Device	Binary Value	Binary Input	Multi-State Value	Multi-State Input	Analog Value
Object Identifier	x	x	x	x	x	x
Object Name	x	x	x	x	x	x
Object Type	x					
System Status	x					
Vendor Name	x					

Vendor Identifier	x					
Model Name	x					
Firmware Revision	x					
Appl Software Version	x					
Location	x					
Description	x					
Protocol Version	x					
Protocol Revision	x					
Services Supported	x					
Object Types Supported	x					
Object List	x					
Max APDU Length Accepted	x					
Segmentation Support	x					
ADPU Timeout	x					
Number of APDU Retries	x					
Max Master	x					
Max Info Frames	x					
Device Address Binding	x					
Database Revision	x					
Present Value		x	x	x	x	x
Status Flags		x	x	x	x	x
Event Flags		x	x	x	x	x
Reliability		x		x		x
Out-of-Service		x	x	x	x	x
Units						x
Priority Array						
Relinquish Default						
Polarity			x			
Active Text		x	x	x	x	
Inactive Text		x	x	x	x	
State Text				x	x	

From a BACnet perspective, the **SBC** appears to be a single BACnet device representing the target drive. Consequently, it provides a Device object.

3.4.2 Device Object Support

The Device Object shall support the following properties:

- Object_Identifier (Device instance* **writable**)
- Object_Name
- Object_Type
- System_Status
- Vendor_Name
- Vendor_Identifier
- Model_Name
- Firmware_Revision
- Application_Software_Version (of SBC software)
- Location (**writable**)
- Description (**writable**)
- Protocol_Version
- Protocol_Revision
- Protocol_Services_Supported
- Protocol_Object_Types_Supported
- Object_List
- Max_APDU_Length_Accepted
- Segmentation_Supported
- APDU_Timeout
- Number_Of_APDU_Retries
- Max_Master (**writable**)
- Max_Info_Frames
- Device_Address_Binding
- Database_Revision

* The Device Instance may be changed in one of two ways:

Write the Object_Identifier to the Device Object. Per the BACnet standard, the Object Identifier consists of the following values:

- A 10-bit object type (Device = 8)
- A 22-bit object instance

Write the Device's Object_Identifier with (8,Instance) to change the Device_Instance. See the BACnet standard for proper encoding.

For simplicity, use Analog Value 1 to change the Device Instance. Write using a REAL data type to the Present_Value of AV1. Any fractional component will be truncated (i.e. 100.35 will be written as 100).

NOTE: Device Instance changes do not take effect until power is cycled.

3.5 Object Support (in general)

The SBC supports a table-based list of BACnet-visible values as described in 6. In addition to a Device object as described in 3.4, the **SBC** supports several standard object types as described below.

Each interface table value is be accessible by BACnet clients as a Present_Value property of a standard object. The interface table slot explicitly defines the object type and instance of the standard object that represents it.

The following properties of those objects are supported. In general, standard object property values other than Present_Value shall be derived as follows:

- Object_Identifier generated automatically from request
- Object_Name from Interface Table
- Polarity always NORMAL
- Description from Interface Table
- Status_Flags always {FALSE, FALSE, FALSE, FALSE}
- Event_State always NORMAL
- Reliability always NO_FAULT_DETECTED
- Out_Of_Service always FALSE
- Units from Interface Table
- Inactive_Text from Interface Table
- Active_Text from Interface Table
- State_Text from Interface Table

3.6 Commandability

The **SBC** does not provide this functionality.

3.7 Writability

Standard object Present_Values are writable only for those slots indicated in the Interface Table. The background processing of writes affecting the drive controller attempts to write changes as soon as possible after a BACnet write has occurred. Except for Present_Value, writable properties in the Device object are non-volatile.

3.8 Segmentation

The **SBC** does not provide this functionality.

4. Configuration

The **SBC** allows configuration of the following BACnet parameters:

- BACnet Device Instance by writing to the Device's Object_Identifier or for simplicity, Analog Value 1
- MS/TP MAC address by configuration through dip switch
- MS/TP baudrate by configuration through dip switch
- MS/TP Max Masters by writing to the Device property

In addition, a non-volatile 16-bit parameter is provided for the **SBC** to keep track of database revisions as required by BACnet.

5. Quick Communication Setup

This section describes the necessary steps to be taken before the BAS Starter BACnet device can be integrated into an MS/TP BACnet segment.

- 1) The SBC comes installed in a BAS Starter. Contact Cerus Industrial for instructions if there is a need to install/reinstall an SBC.
- 2) Turn off all power to the BAS Starter.
 - a) Remove the voltage terminal from the BAS Starter.
 - b) Always use a properly rated voltage sensing device to confirm that power is off.
- 3) Follow instructions to attach an anti-static or grounding strap (customer supplied) before accessing the BAS Starter.
- 4) Locate the SBC board within the BAS Starter and verify the following pre-connected interfaces are intact:
 - a) Current Sensor is connected to POF Input Terminal
 - b) Control Power Transformer secondary output is connected to the 24V Input Terminal
- 5) Select DIP switch settings based upon DIP switch definitions in section 2.1.2
 - a) Baud rate DIP switch
 - i) Select Baud Rate and Action to take upon Loss of BACnet Communications
 - b) Device Address DIP switch
 - i) Select unique MAC ID for each starter on MS/TP segment
 - (1) No MAC ID can be larger than MAX Master value on any device
 - (2) For an efficient token passing configuration, always set MAC IDs to the lowest contiguous values and set MAX Master to the lowest possible value.
 - c) Default Term/Bias DIP Switch
 - i) Select Ground Connection and Resistors. Devices at each end of MS/TP segment should have network termination resistors enabled.
- 6) Connect each BAS Starter (one at a time) to the network as shown in figures 6 & 7. (As you do this, insure that network termination resistors are enabled for devices at ends of segment.)
- 7) For each BAS Starter, perform the following:
 - a) Check that network termination resistors are enabled at each end of network
 - b) Replace the voltage terminal into the BAS Starter
 - c) Write unique Device Instance via BACnet
 - d) Write Max_Master via BACnet
 - e) For an efficient token passing configuration, always set MAC IDs to the lowest contiguous values and set MAX Master to the lowest possible value.
 - f) Cycle power on BAS Starter to initialize Device Instance and Max_Master values
 - g) Confirm proper BACnet communication

6. Interface Table

This table represents the mapping from internal values in the starter controller to BACnet-visible object instances. All Present_Values are readable. Only those marked W are writable. All writable values are assumed to be volatile (lost across power off cycles) unless marked WN. All Value Objects are objects that can be modified via the BACnet interface. "Inputs" are used as referenced from the Controller point of view. For example, an input describes data flow from the Starter to the Controller.

6.1 Binary Value Object Instance Summary

Instance ID	Object Name	Description	Active/Inactive Text	Present Value Access Type
BV1	AutoStartCommand	<p>Auto Start Command</p> <p>This command commands the starter to start. Control requires Auto Mode selected from keypad. Change of mode will reset internal BACnet command to Off. Damper must be closed for motor to start.</p> <p>When LossOfCommsStop on Bacnet switch is True, a AutoStartCommand value of Off will be sent to the Starter upon Loss of BACnet Communications</p>	On/Off	W
BV2	ClearCounts	<p>Clear Counts</p> <p>This command commands the reset of the run time count, overload reset count and power failure count.</p>	Clear/Don't Clear	W

6.2 Binary Input Object Instance Summary

Instance ID	Object Name	Description	Active/Inactive Text	Present Value Access Type
BI1	ProofOfFlow	Proof of Flow Indicates positive proof of flow of motor.	On/Off	R
BI2	StarterMode	Starter Mode Indicates whether starter is running regardless of how start was initiated.	Running/Not Running	R
BI3	WetAutoInput	Wet Auto Input When enabled by program switch 2 on the starter board, this indicates the status of Wet Auto Customer Input.	On/Off	R
BI4	FiremansOverride	Firemans Override Input When enabled by program switch 2 on the starter board, this indicates the status of Fireman's Override Customer Input.	On/Off	R
BI5	DryAutoInput	Dry Auto Input When enabled by program switch 3 on starter board, this indicates the status of the Dry Auto Customer input.	On/Off	R
BI6	NetAutoInput	Network Auto Input Indicates the status of Auto Start Command via BACnet.	On/Off	R
BI7	ShutdownInput	Shutdown Input Indicates the status of the Shutdown Input from Customer. Starter will remain off no matter what the current mode is (except Fireman's Override) when Shutdown Input is On.	On/Off	R

BI8	OverloadFault	Overload Fault Indicates the status of the Overload Alarm.	Alarm/No Alarm	R
BI9	DamperContactorFault	Damper or Contactor Fault Indicates an alarm when starter has been running at least 2 minutes and Proof of Flow has not been detected since the starter was started.	Alarm/No Alarm	R
BI10	UnexpectedProofOfFlowFault	Unexpected Proof of Flow Fault Indicates an alarm when Proof of Flow is detected, but Starter is not running.	Alarm/No Alarm	R
BI11	CyclingFault	Cycling Fault Indicates an alarm when motor starts and stops occur at a rate of over 1200/hour over a 10 second period. The operator can reset the fault by depressing the OFF button for 10 seconds on the keypad.	Alarm/No Alarm	R
BI12	PowerFault	Power Fault Indicates an alarm due to loss of power (before reset to appropriate mode) when Power Fail Mode dip switches (6,7,8) set to modes (ON,OFF,ON), (ON,OFF,OFF), (OFF,ON,ON), respectively.	Alarm/No Alarm	R
BI100	LossOfCommsStop	Stop on Loss of Communications Indicates that Network Auto Input value of False will be sent to the Starter upon Loss of BACnet Communications. (Reflects BACnet dip switch setting)	True/False	R

BI101	RecycleEnable	<p>RecycleEnable</p> <p>When enabled, the starter mode is set to OFF when there are greater than a rate of 1200 motor starts and stops per hours over a 10 sec period. Reflects starter dip switch setting.</p>	Enabled/Disabled	R
BI102	WetInputEnable	<p>Wet Auto Input enabled</p> <p>When True, indicates that Wet Auto Input is enabled. When False, indicate that Fireman's Override is enabled. Reflects starter board dip switch setting.</p>	True/False	R
BI103	DryContactEnable	<p>Dry Contact Enable</p> <p>Indicates that the Auto Dry Input contact is enabled. Reflects starter board dip switch setting.</p>	Enabled/Disabled	R
BI104	EPO_FOPriority	<p>Indicates if Emergency Power Off (EPO) has priority over Firemans Override (FO) in the case of an Industrial Automation Starter (IAS)</p> <p>(Reflects factory programming of starter as IAS)</p>	True/False	R
BI105	KeypadDettached	<p>Indicates that keypad is dettached.</p>	True/False	R

6.3 Multi-state Input Object Instance Summary

Instance ID	Object Name	Description	Active/Inactive Text	Present Value Access Type
MI1	ModeStatus	Mode Status Indicates the current mode that the Starter is running in.	1 Off 2 Hand 3 Auto	R
MI2	KeypadStatus	Keypad Status Indicates the current mode as commanded from keypad.	1 Off 2 Hand 3 Auto	R
MI100	EOLMode	Electronic Overload Mode Reflects starter board dip switch setting switches 4,5.		R
MI101	PowerUpMode	Power Up Mode Reflects starter board dip switch setting switches 6-8.		R

6.4 Analog Value Object Instance Summary

Instance ID	Object Name	Description	Units	Present Value Access Type
AV1	DeviceInstance	Indicates the Device Instance assigned to the Starter. This value must be unique inter-network wide. Range 1-4194302.	N/A	WN
AV2	CommTimeout	Lost Communication Timeout Indicates in seconds the time after which there is assumed to be no communications with a BACnet client device on the BACnet port (1-120)	Seconds	W
AV3	RunTimeCount	Indicates, in hours, the starter's accumulated run time since the last reset. To reset, write 0.0 to the PRESENT_VALUE property of AV3.	Hours	W
AV4	OverloadResetCount	Indicates the Overload Reset Count. To reset, write 0.0 to the PRESENT_VALUE property of AV4.	None	W
AV5	PowerFailureCount	Indicates the Power Failure Count. To reset, write 0.0 to the PRESENT_VALUE property of AV5.	None	W

7. Diagnostics

- Normal Operation
 - The CPU LED blinks at a one sec rate
 - The TX, RX and TOK LEDs will cycle on and off at a rate depending on traffic
 - The ERR LED will be off
 - The F1 and F2 LEDs will blink at approximately a 2 second rate

- Unable to Communicate
 - BACnet Controller receives errors when trying to communicate with BAS Starter
 - BAS Starter appears as only device on network when it is not (TX slightly flickers, RX is off and TOK is on)
 - Solution:
 - Check that RS-485 communication wires are not swapped
 - Check that baud rate setting is correct
 - Check that each device has a unique MAC ID
 - Check that all MAC IDs fall within the smallest MAX MASTER setting for any device on network
 - Check that each device has a unique Device Instance
 - Check that cabling is properly connected

- No Power to Board
 - The Power LED is off
 - Solution:
 - Check 24 VAC Input connection to SBC
 - Check voltage input to BAS Starter

- Error in Communications to BAS Starter Board
 - The ERR LED is on
 - Solution:
 - Check for loose connection to BAS Starter Board
 - Resolve problem with BAS Starter Board

- Auto Start Command unexpectedly turns off
 - BV1 Auto Start Command changes to off
 - Starter stops running
 - Solution:
 - Check Loss on Communications Setting on Baud Rate DIP Switch
 - Check AV2 Comm Timeout
 - If Loss on Comms Switch set to ON, and I/O messages not occurring within Comms Timeout period, Auto Start Command changes to off and Starter may stop running if no other Customer Inputs are sending Start Command

- Intermittent Communication Problems
 - Possible network/wiring issue
 - Solution:
 - Check for loose RS-485 connections
 - Check for missing or misplaced network terminations (devices at each end of the network should have termination resistors)
 - Check for wear on wires
 - Check for insufficient shield and grounding
 - As recommended, try setting the MAC IDs to the lowest contiguous values and set MAX Master to the lowest possible value.