

LG Dynamic Braking Unit

SV-DBU-U Series



Important precautions

SV-DBU-U series is designed to use with LG inverter SV-IS5 and SV-IH series.

This manual describes the safety instructions that must be followed when installing, operating, and servicing. Read this manual completely before installing. The unit contains high voltage that can cause electric shock resulting in personal injury or loss of life.

Safety Instructions

- Always follow safety instructions to prevent accidents and potential hazards from occurring.
- In this manual, safety messages are classified as follows :

WARNING Improper operation may result in serious personal injury or death.

CAUTION Improper operation may result in slight to medium personal injury or property damage.

- Throughout this manual we use the following two illustrations to make you aware of safety considerations

Identifies potential hazards under certain conditions. Read the message and follow the instructions carefully.

Identifies shock hazards under certain conditions. Particular attention should be directed because dangerous voltage may be present.

WARNING

- Do not remove the cover while power is applied or the unit is in operation.**
Otherwise electric shock could occur.
- Do not run the DB unit with the front cover removed.**
Failure to comply could result in electric shock due to high voltage terminals or charged capacitor exposure.
- Do not remove the cover except for periodic inspections or wiring, even if the input power is not applied.**
Otherwise, you may access the charged circuits and get an electric shock.
- Wiring and periodic inspections should be performed at least 10 minutes after disconnecting the input power and after checking the DC link voltage is discharged with a meter (below DC 30V).**
Otherwise, you may get an electric shock.
- Operate the switches with dry hands.**
Otherwise, you may get an electric shock.
- Do not use the cable when its insulating tube is damaged.**
Otherwise, you may get an electric shock.
- Do not subject the cables to scratches, excessive stress, heavy loads or pinching.**
Otherwise, you may get an electric shock.

CAUTION

- Install the DB unit on a non-flammable surface. Do not place flammable material nearby.**
Otherwise, fire could occur.
- Disconnect the input power if the inverter or DB unit gets damaged.**
Otherwise, it could result in a secondary accident and fire.
- Do not connect the braking resistor directly to the DC terminal (P/B1, N) of the DB unit.**
Otherwise, fire could occur.
- Do not touch DB unit, Inverter and the resistor right after the power is turn off.**
The resistor is still hot.
- Do not allow lint, paper, wood chips, dust, metallic chips or other foreign matter into the DB unit.**
Otherwise, fire or accident could occur.
- Do not apply power to a damaged inverter or to DB unit with missing parts even if the installation is complete.**
Otherwise, electric shock or fire could occur.

1. Nomenclature

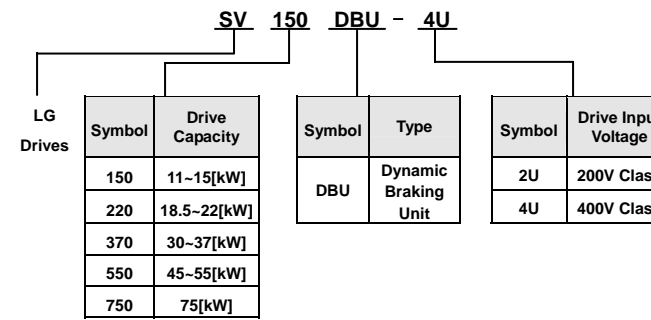

2. Specifications

2.1 200V Class

Spec.	Type	SV150DBU -2U	SV220DBU -2U	SV370DBU -2U	SV550DBU -2U
Max. DC Input Voltage		DC 400V			
Applicable Drive Capacity [kW]		11	15	18.5	22
Braking Resistor	Wattage	3.2 [KW]	4.8 [KW]	6.4 [KW]	9.6 [KW]
	Minimum Resistance	8.5 [Ω]	5.7 [Ω]	4.2 [Ω]	2.8 [Ω]

2.2 400V Class

Spec.	Type	SV150DBU -4U	SV220DBU -4U	SV370DBU -4U	SV550DBU -4U	SV750DBU -4U
Max. DC Input Voltage		DC 800V				
Applicable Drive Capacity		11	15	18.5	22	30
Braking Resistor	Wattage	3.2 [KW]	4.8 [KW]	6.4 [KW]	9.6 [KW]	12.8 [KW]
	Minimum Resistance	8.5 [Ω]	5.7 [Ω]	4.2 [Ω]	2.8 [Ω]	8.4 [Ω]

2.3 General Specifications

Average Braking Torque	100%	
Enable Duty	10%	
Parallel Connection	Connectable up to 3 units in parallel	
Maximum Turn On Time	6 seconds	
Output Signal	Heat Sink Overheat, Fuse Open, OC Trip	
Protection	Heat Sink Overheat Protection, Over-Current Protection, Output Short Circuit Protection	
Environmental Conditions	Ambient Temperature	-10°C ~ 40°C
	Humidity	Less Than 90 % RH Max. (Non-Condensing)
	Altitude	1,000m above sea level
	Cooling Method	Natural Convection
	Location	No Corrosive Gas, Combustible Gas, Oil mist or Dust

3. Installation

- Environmental Conditions
 - Do not mount the unit in direct sunlight. Isolate the unit from excessive vibration.
 - Protect from moisture, dust, metallic particles, corrosive gases and liquid. Install the units on a non-flammable material and as smooth as possible.
 - In case of installing many units in a panel, consider the airflow for power dissipation. (see below figures for proper installation)

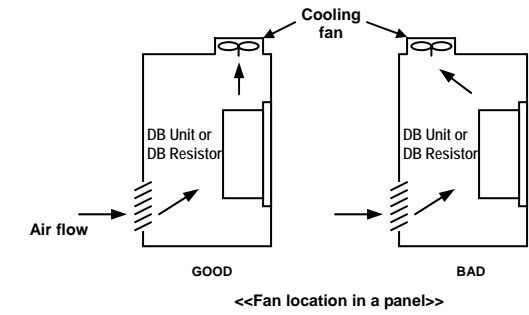
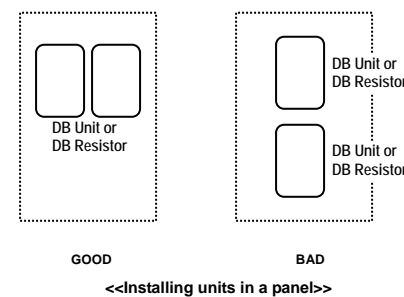

- Mounting
The units must be mounted vertically with sufficient room (horizontally and vertically) from adjacent equipment.

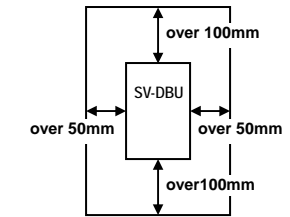

4. Terminal Configuration

- 1) Power Terminals

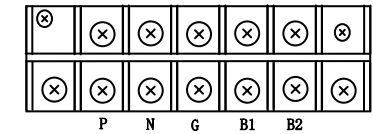

Terminal	Description
P	DC (+) input. Connect to "P2" or "P" terminal of the drive
N	DC (-) input. Connect to "N" terminal of the drive
G	Ground Terminal
B1	Connect to braking resistor
B2	Connect to braking resistor

- 2) Control Terminals

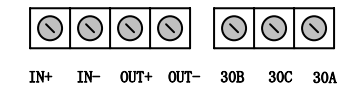

Terminal	Function
IN+	Slave turn on signal input (when "Slave Mode" selected)
IN-	Slave turn on signal input (when "Slave Mode" selected)
OUT+	Slave turn on signal output (when "Master Mode" selected)
OUT-	Slave turn on signal output (when "Master Mode" selected)
30A	Fault signal output
30B	30A : Normal open contact
30C	30B : Normal close contact
	30C : Common terminal

(Refer to sec. 7 for details of Master/Slave Operation)

5. Terminal Wiring

- The SV-IH series has two kinds of power terminal configurations. Make sure the wiring according to drive capacity.
- SV030IH-4, SV037IH-4, SV045IH-4, SV055IH-4 units do not provide terminals for DC reactor connection.

1) Wiring Drive, DB unit and DB resistor

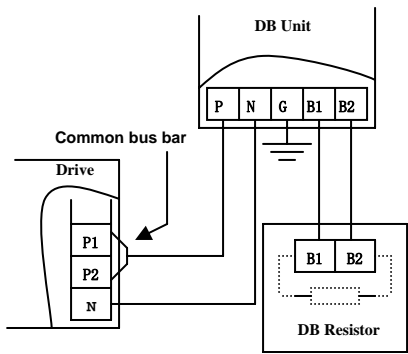

2) Wiring Drive, DB unit, DB resistor and DC reactor

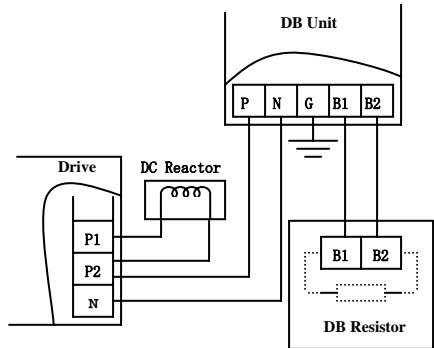

6. Basic Wiring

1) Single Operation

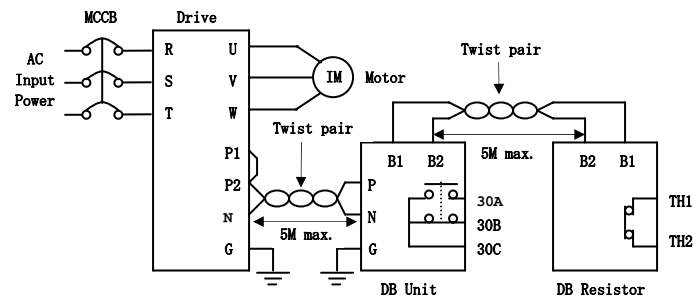

*) The SV030/037/045/055DBH-4 units provide terminal "P" only, without terminal "P1" and "P2". Please refer to "2) Wiring Drive, DB unit and DB resistor for SV030/037/045/055IH-4" for correct wiring.

- Use twist wire shorter than 10m between drive, DB unit and DB resistor.
- For master/slave operation, the control wire should be shorter than 2m with twist wire.
- Be sure to earth terminal "G" of drive and DB unit.
- Wire Size: Use Copper Conductors Only

	DB Unit	Wire size mm ² (AWG)
200V	SV150DBU-2U	5.5 mm ² (10AWG)
	SV220DBU-2U	8.0 mm ² (8AWG)
	SV370DBU-2U	14.0 mm ² (6AWG)
	SV550DBU-2U	14.0 mm ² (6AWG)
400V	SV150DBU-4U	5.5 mm ² (10AWG)
	SV220DBU-4U	5.5 mm ² (10AWG)
	SV370DBU-4U	5.5 mm ² (10AWG)
	SV550DBU-4U	8.0 mm ² (8AWG)
	SV750DBU-4U	14.0 mm ² (6AWG)

■ Tightening Torque for power terminal connection: 24 In-Lb

7. Master / Slave Operation

- In case of parallel operation of two braking units, the one must be set at "Master" and the other at "Slave". (When one braking unit is operated it must be set at "Master" : Factory default – "Master")
- How to set to Master (on PCB)
 - Set the "Select Switch JP1" as below figure.

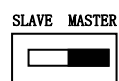

3) How to set to Slave (on PCB)

- Set the "Select Switch JP1" as below figure.

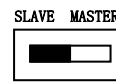

4) Connection between Master and Slave

- Set one DB unit to "Master" and the other to "Slave".
- Connect "OUT+" terminal of Master to "IN+" terminal of Slave and "OUT-" terminal of Master to "IN-" terminal of Slave.

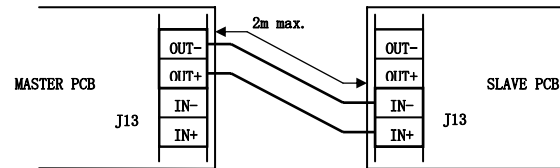

5) Connecting 3 DB Units

- Set one DB unit to "Master" and others to "Slave".
- Connect "OUT+" terminal of Master to "IN+" terminal of Slave and "OUT-" terminal of Master to "IN-" terminal of Slave, respectively.

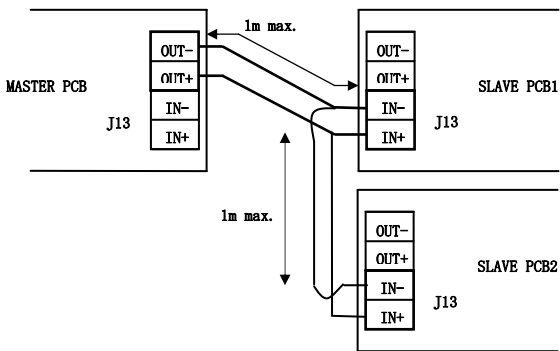

6) Master/Slave Operation

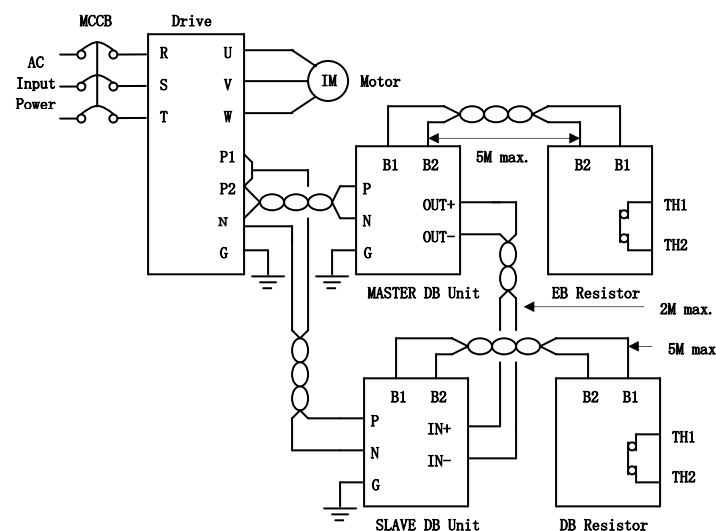

8. Combination of DB Units Corresponding to Drive Capacity

1) Combination of Braking Units

200V Class		11	15	18.5	22	30	37	45	55
Applicable Drive [KW]		11	15	18.5	22	30	37	45	55
Braking Unit		SV150DBU-2U	SV220DBU-2U	SV370DBU-2U	SV550DBU-2U				
Braking Resistor		3.2KW 8.5Ω	4.8KW 5.7Ω	6.4KW 4.2Ω	9.6KW 2.8Ω				

Applicable Motor [KW]	11	15	18.5	22	30	37	45	55
-----------------------	----	----	------	----	----	----	----	----

■ 400V Class

Applicable Drive [KW]	11	15	18.5	22	30	37
Braking Unit	SV150DBU-4U	SV220DBU-4U	SV370DBU-4U			
Braking Resistor	3.2KW 33.9Ω	4.8KW 22.8Ω	6.4KW 16.9Ω			
Applicable Motor [KW]	11	15	18.5	22	30	37

Applicable Drive [KW]	45	55	75	90 ~ 160	220
Braking Unit	SV550DBU-4U	SV750DBU-4U	SV750DBU-4U * 2 EA	SV750DBU-4U * 3 EA	
Braking Resistor	9.6KW 11.4Ω	12.8KW 8.4Ω	12.8KW 8.4Ω * 2 EA	12.8KW 8.4Ω * 3 EA	
Applicable Motor [KW]	45	55	75	90 ~ 160	220

● See below for the combination of DB Units and DB resistors.

2) Combination of 200V Class Units

- ▶ Drive Capacity: 30[kW] ~ 37[kW]
- ▶ Drive Capacity: 45[kW] ~ 55[kW]

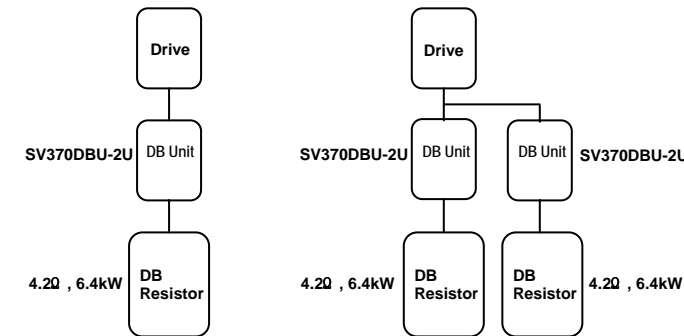

3) Combination of 400V Class Units

- ▶ Drive Capacity: 30[kW] ~ 37[kW]
- ▶ Drive Capacity: 45[kW] ~ 75[kW]

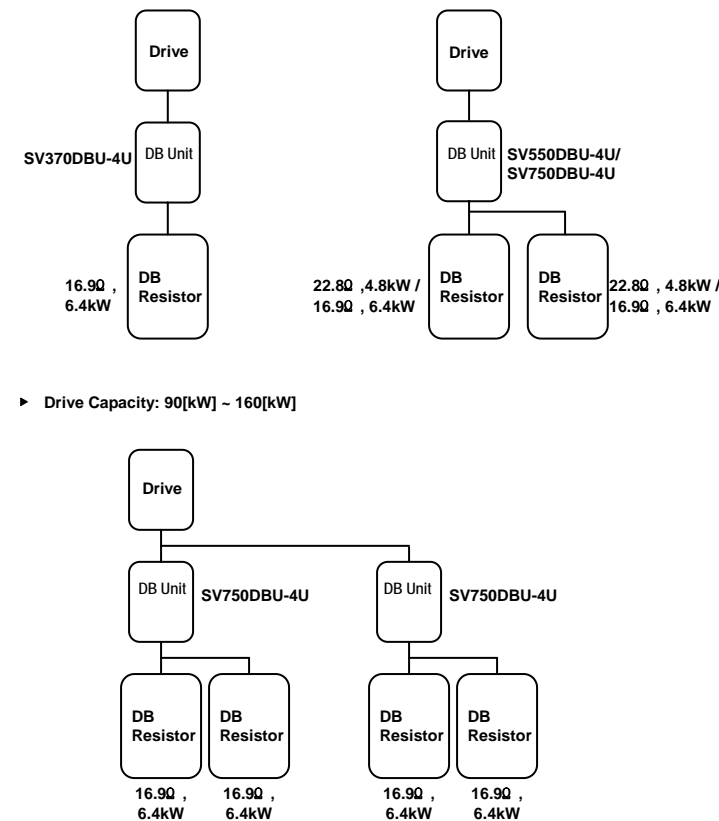

▶ Drive Capacity: 220[kW]

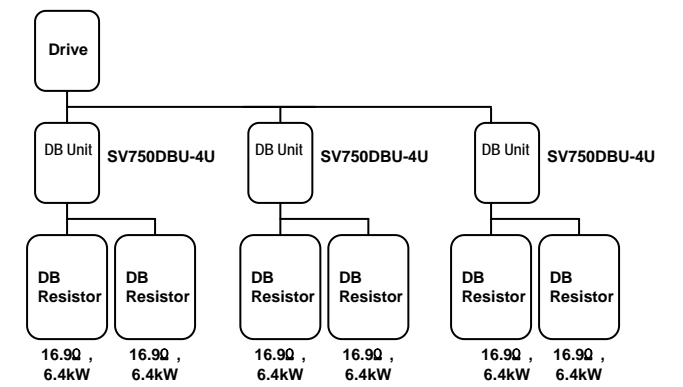

9. Display LED and Fault Reset

The DB Unit have four LEDs on the frontcover. The green LEDs display braking operation. The red LEDs display main power input and fault status of the unit.

Display	Function
POWER (RED)	This LED is lit when the input power of the unit is applied.
RUN (GREEN)	This LED is lit when the unit is in the braking operation.
OHT (RED)	This LED is lit and cut off (trip) the output when the heat sink of the unit is over heated.
OCT (RED)	This LED is lit when an excessive current flows through the IGBT and the unit turns off the output to protect the unit.
FOT (RED)	This LED is lit when the internal protective fuse is opened.

10. Dimensions

